

## PLSC CIRCUIT FOR IMMERSION FIRED PRODUCTS

---

### ADJUSTING THE TIMER SET-POINT FOR SIEMENS PLSC TIMER

The PSLC Timer for the Immersion fired products, if provided, will ship with the PLSC timing sequence set at one minute. This is an adjustable time period and can be changed at any time. The following instructions describe how to change this set-point.

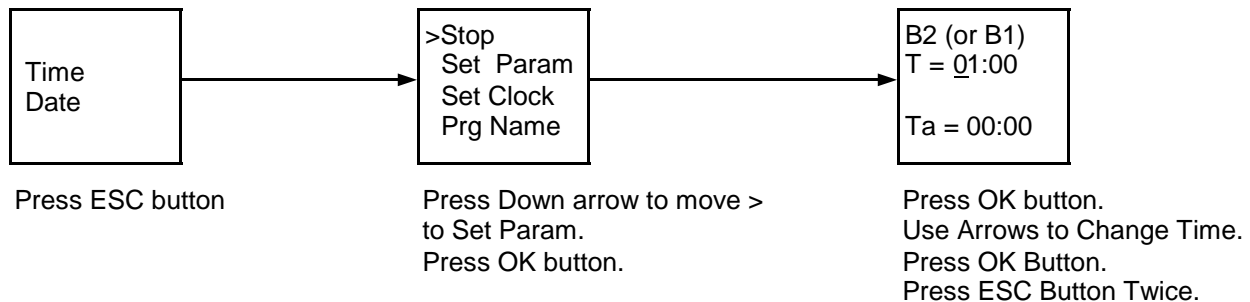

**CAUTION: DO NOT ALTER THE VALUES FOR B3 OR B4.**

---

### SETTING THE CLOCK FOR SIEMENS PLSC TIMER

(This is not required for proper operation of Timer)

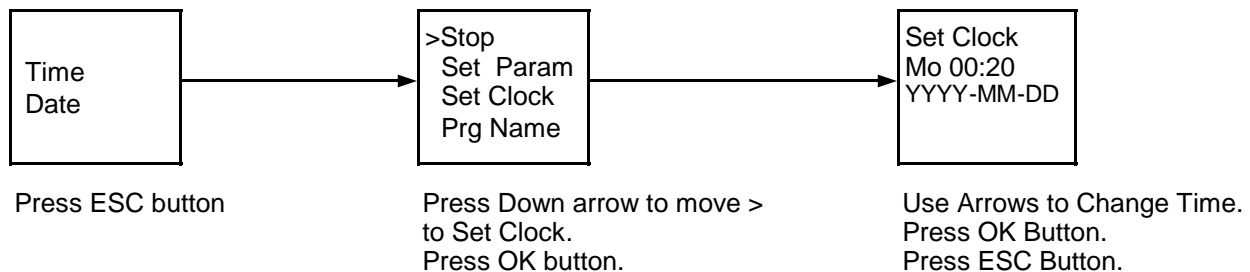

Please consult the factory if you experience problems with the timer. If the programming accidentally get changed it can be reset with the use of a memory chip that can be supplied by the factory to restore the unit to factory settings.